



深圳市环芯半导体有限公司

电话 Tel: 0755-28149272

传真 Fax: 29018191

地址 Add: 深圳市宝安区龙华东环一路港之都大厦 633

邮编 Ps.: 518109

Http://www.ATChip.Com

Combinations of TG1 and TG5 to trigger maximum 64 Voice Group.

- CPU Command Mode :

User command through TG1, TG2, TG5 & TG6 with serial CPU Interface to control the Multi-Playback function.

● **Output status** (for each Output pin):

- A. Stand by Status. (High/Low Status)
- B. Busy Low Active.
- C. Busy High Active.
- D. LED Flash at 6 Hz.
- E. LED Flash at 3 Hz.
- F. LED Flash at 1.5 Hz.
- G. LED Flash at 0.75 Hz.

● **Play rate level** :

AC8040 can provide different play rate in one code as follow

Play rate(K)	Play rate(K)
3	6
3.2	6.4
3.31	6.85
3.42	7.38
3.55	8
3.69	8.72
3.84	9.6
4	10.66
4.17	12
4.36	13.71
4.57	16
4.8	19.2
5.05	24
5.33	
5.64	



深圳市环芯半导体有限公司

电话 Tel: 0755-28149272

传真 Fax: 29018191

地址 Add: 深圳市宝安区龙华东环一路港之都大厦 633

邮编 Ps.: 518109

Http://www.ATChip.Com

◆ AC8040 Pad Location

CHIP SIZE: (0, 0) (1730,1196) UM

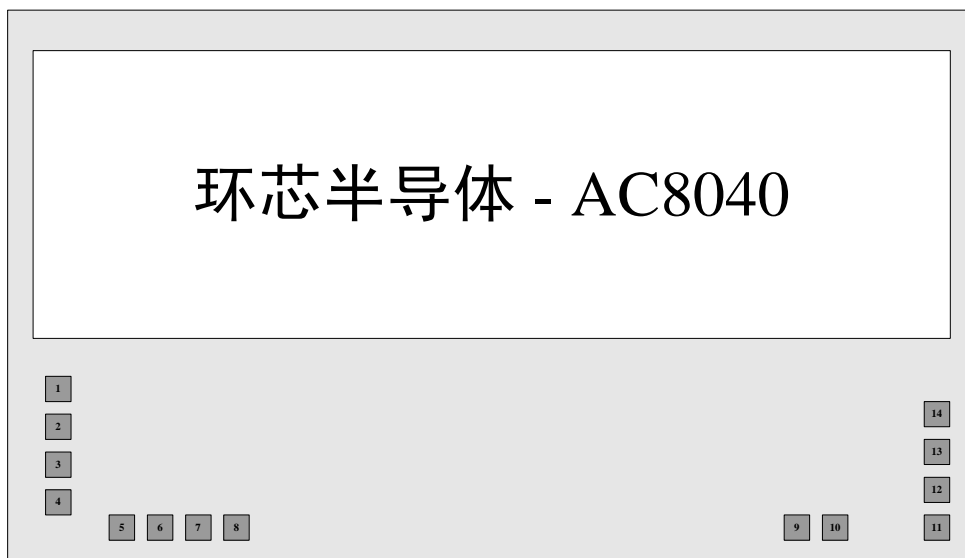

NO	PAD NAME	X	Y	NO	PAD NAME	X	Y
1	TG2	-755	-224	8	TG12	-320	-507
2	TG1	-755	-314	9	VSS	192	-507
3	TG5	-755	-404	10	VSS	281	-507
4	TG6	-755	-494	11	PWM2	759	-529
5	TG7	-590	-507	12	PWM1	759	-412
6	TG8	-500	-507	13	VDD5	794	-325
7	TG11	-410	-507	14	VDD	794	-240



深圳市环芯半导体有限公司

电话 Tel: 0755-28149272

传真 Fax: 29018191

地址 Add: 深圳市宝安区龙华东环一路港之都大厦 633

邮编 Ps.: 518109

Http://www.ATChip.Com

◆ PIN Descriptions

PIN NAME	I/O	Function
TG1	INPUT	Key Stand-alone Trigger Mode : TG1 is used to trigger the maximum 32 Voice Group one by one sequentially.
		Serial Trigger Mode : TG1 is used to trigger the maximum 64 Voice Group.
		CPU Command Mode : TG1 is used as Data Input Pin (DIO1).
TG2	INPUT	Key Stand-alone Trigger Mode : TG2 is used to trigger the maximum 21 Voice Group one by one sequentially.
		CPU Command Mode : TG2 is used as Clock Pin (CLK).
TG5	INPUT	Key Stand-alone Trigger Mode : TG5 is used trigger Only One Group.
		Serial Trigger Mode : TG5 is used to trigger the maximum 64 Voice Group
		CPU Command Mode : TG5 is used as Data Input Pin (DIO2).
		As a RESET PIN
	OUTPUT	As Output PIN , Output the BUSY or Flash Signal .
TG6	INPUT	Key Stand-alone Trigger Mode : TG6 is used trigger Only One Group.
		CPU Command Mode . TG6 is used as Selected Pin (CS).
	OUTPUT	As Output PIN , Output the BUSY or Flash Signal.
TG7	INPUT	Key Stand-alone Trigger Mode : TG7 is used trigger Only One Group.
	OUTPUT	As Output PIN , Output the BUSY or Flash Signal.
TG8	INPUT	Key Stand-alone Trigger Mode : TG8 is used trigger Only One Group.
	OUTPUT	As Output PIN , Output the BUSY or Flash Signal.
TG11	INPUT	Key Stand-alone Trigger Mode : TG11 is used trigger Only One Group.
	OUTPUT	As Output PIN , Output the BUSY or Flash Signal.
TG12	INPUT	Key Stand-alone Trigger Mode : TG12 is used trigger Only One Group.



深圳市环芯半导体有限公司

电话 Tel: 0755-28149272

传真 Fax: 29018191

地址 Add: 深圳市宝安区龙华东环一路港之都大厦 633

邮编 Ps.: 518109

Http://www.ATChip.Com

	OUTPUT	As Output PIN , Output the BUSY or Flash Signal.
PWM1	OUTPUT	As a PWM PIN , can Directly drive the Speaker .
PWM2	OUTPUT	As a PWM PIN , can Directly drive the Speaker .
		As a DAC PIN , 8 bit D/A Current Output.
VDD5	INPUT	Power Supply PIN
VDD	INPUT	Power Supply PIN , Connected with VDD5 @ 2.4~3.6 V Working Voltage.
		Power Supply PIN , Connected with a 0.1 uF to VSS. @3.6~5V Working Voltage.
VSS	INPUT	Connected to Ground.



深圳市环芯半导体有限公司

电话 Tel: 0755-28149272

传真 Fax: 29018191

地址 Add: 深圳市宝安区龙华东环一路港之都大厦 633

邮编 Ps.: 518109

Http://www.ATChip.Com

◆ AC8040 Application Circuit

AC8040 3V Stand-alone Mode

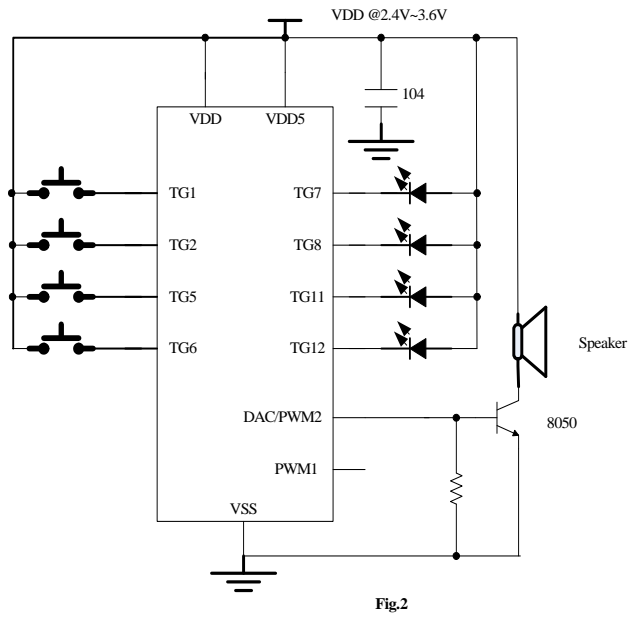
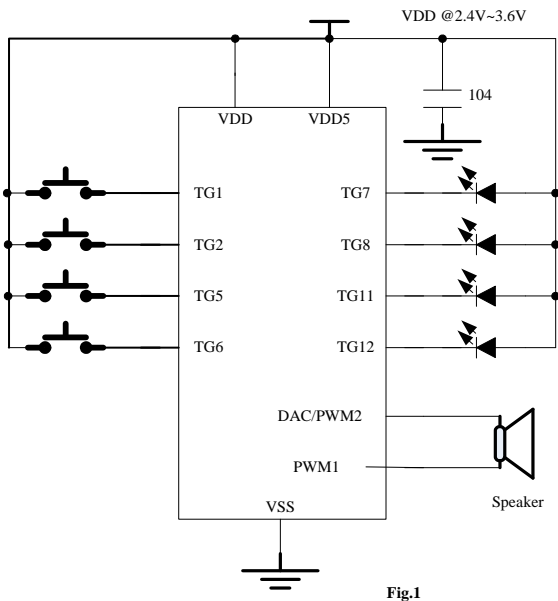

AC8040 5V Stand-alone Mode

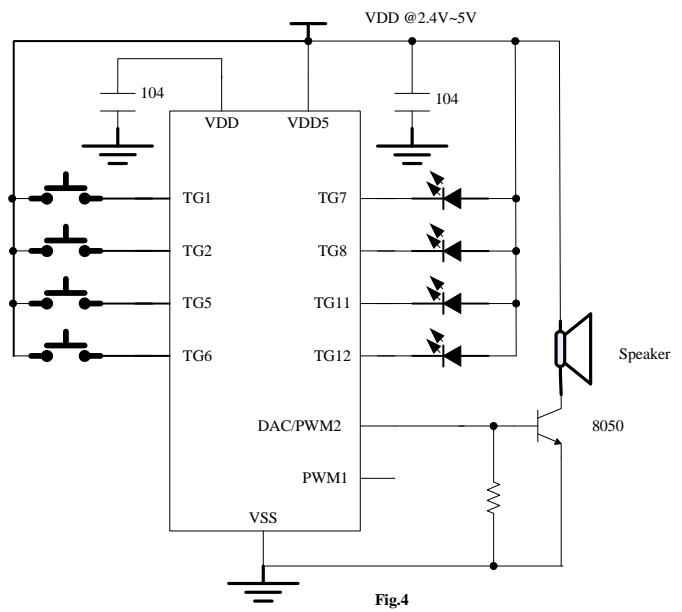
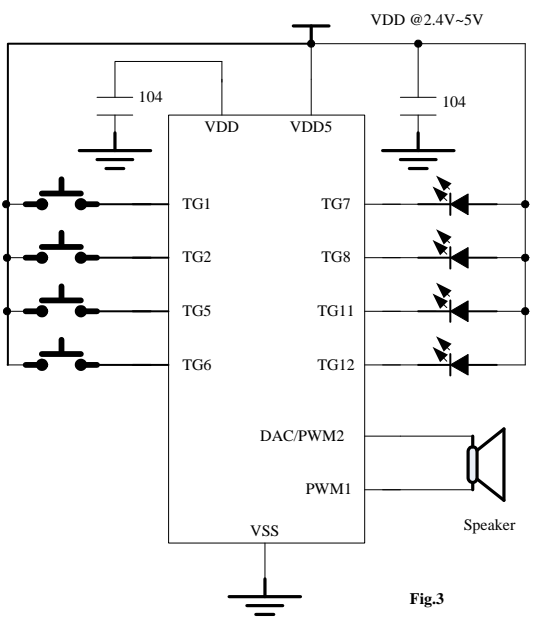



深圳市环芯半导体有限公司

电话 Tel: 0755-28149272

传真 Fax: 29018191

地址 Add: 深圳市宝安区龙华东环一路港之都大厦 633

邮编 Ps.: 518109

Http://www.ATChip.Com

AC8040 3V Serial Mode

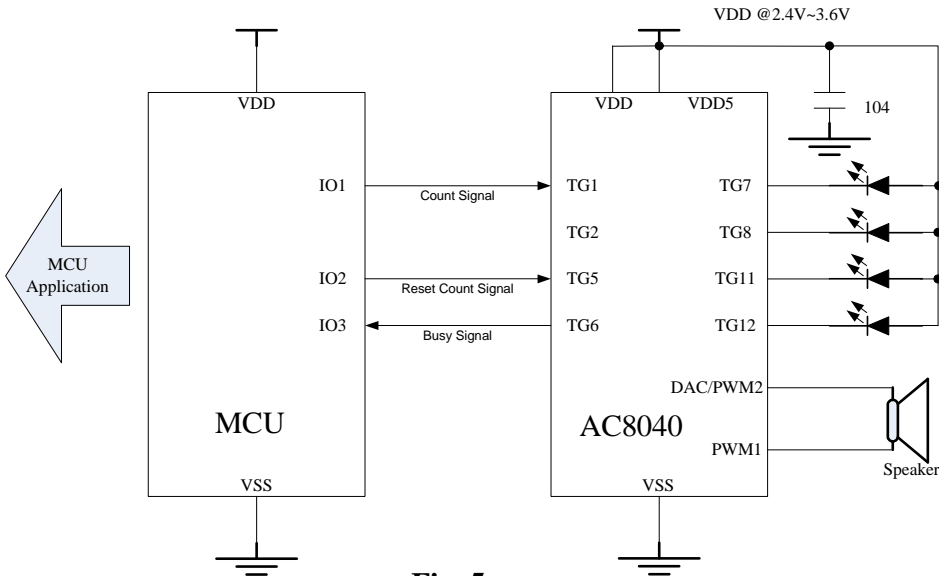

Fig. 5

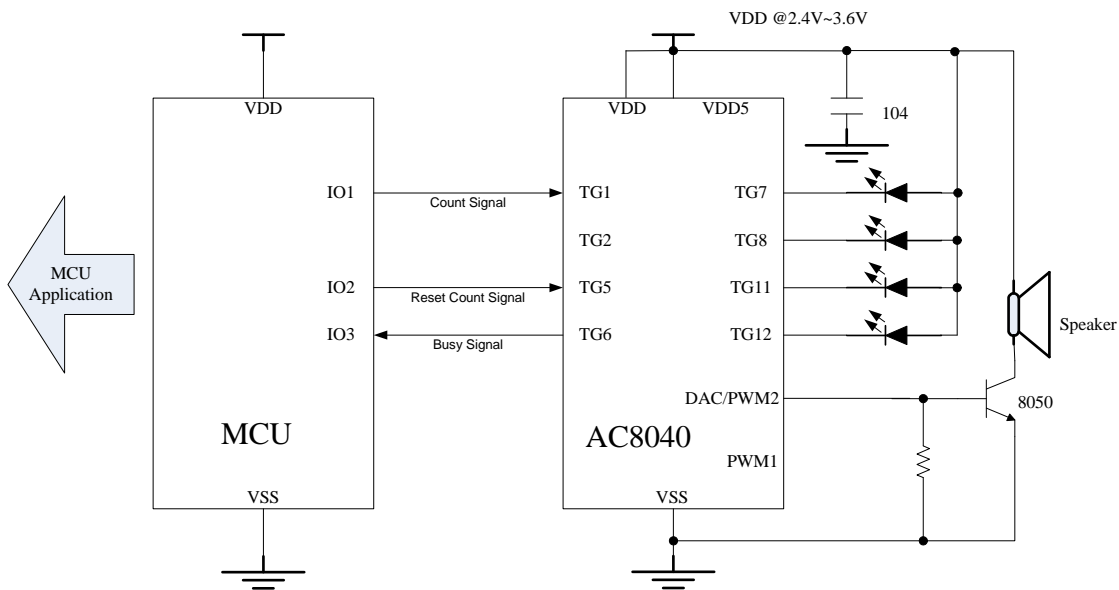

Fig. 6



深圳市环芯半导体有限公司

电话 Tel: 0755-28149272

传真 Fax: 29018191

地址 Add: 深圳市宝安区龙华东环一路港之都大厦 633

邮编 Ps.: 518109

Http://www.ATChip.Com

AC8040 5V Serial Mode

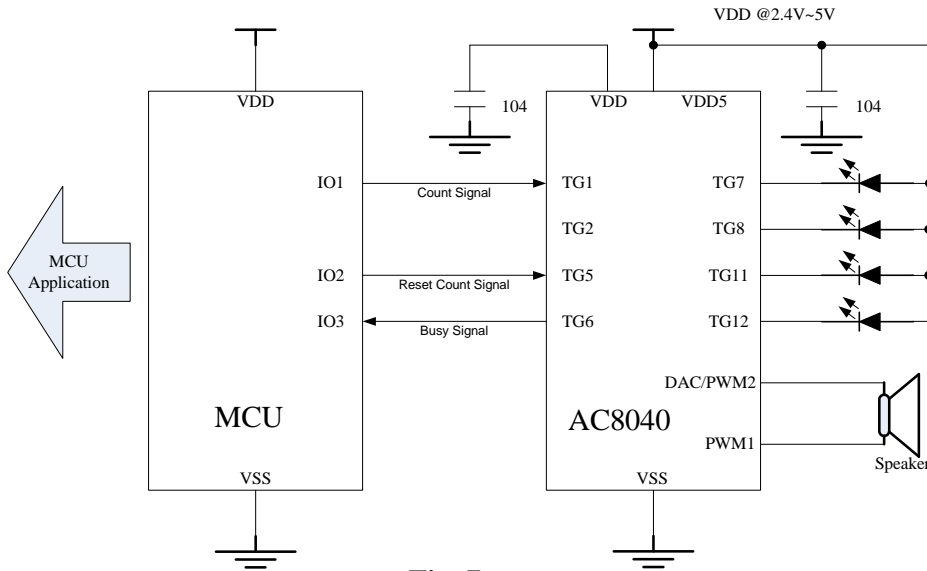

Fig. 7

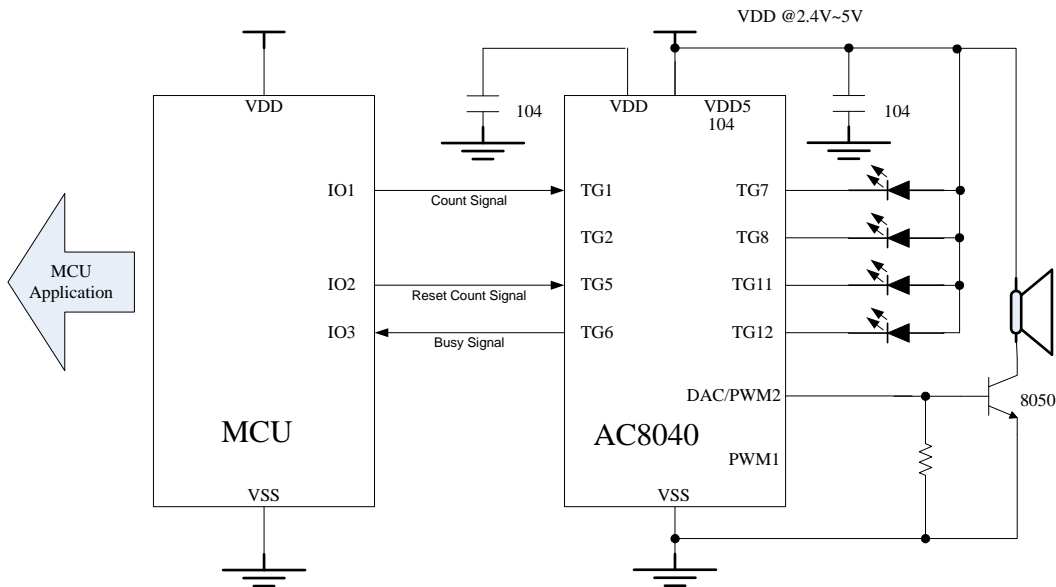

Fig. 8



深圳市环芯半导体有限公司

电话 Tel: 0755-28149272

传真 Fax: 29018191

地址 Add: 深圳市宝安区龙华东环一路港之都大厦 633

邮编 Ps.: 518109

Http://www.ATChip.Com

AC8040 3V CPU Mode

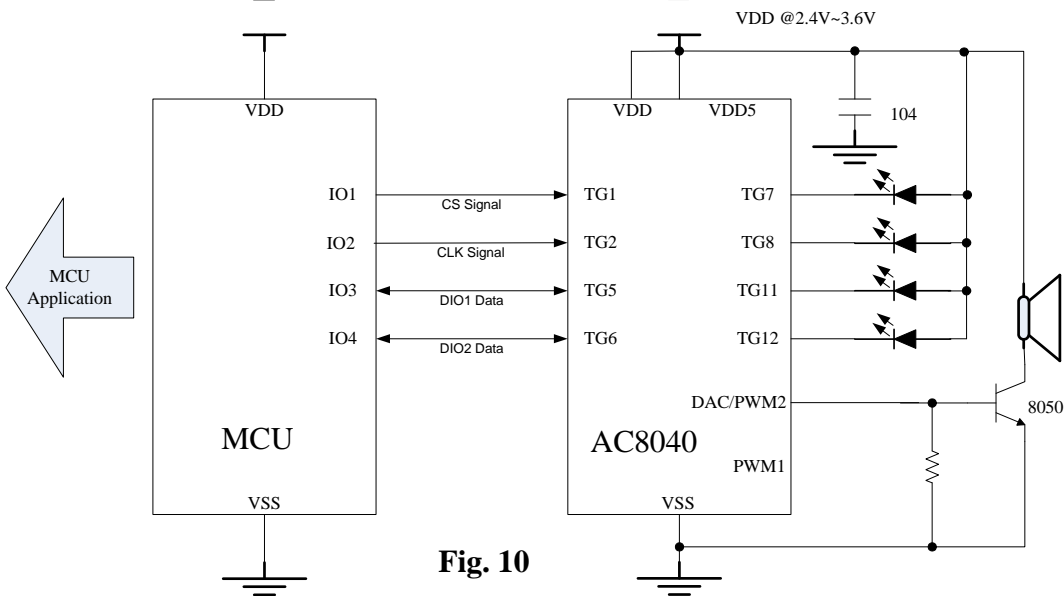
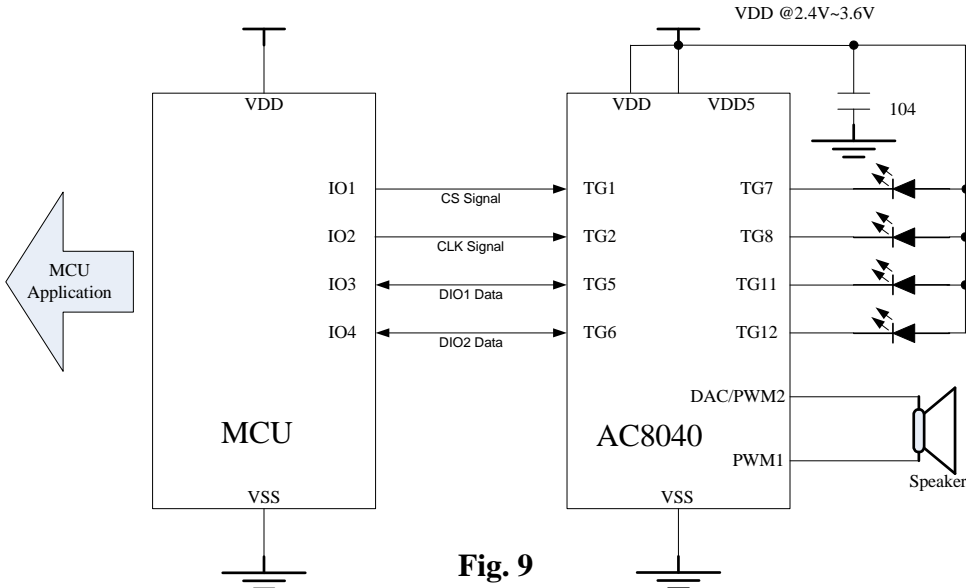



深圳市环芯半导体有限公司

电话 Tel: 0755-28149272

传真 Fax: 29018191

地址 Add: 深圳市宝安区龙华东环一路港之都大厦 633

邮编 Ps.: 518109

Http://www.ATChip.Com

AC8040 3V CPU Mode

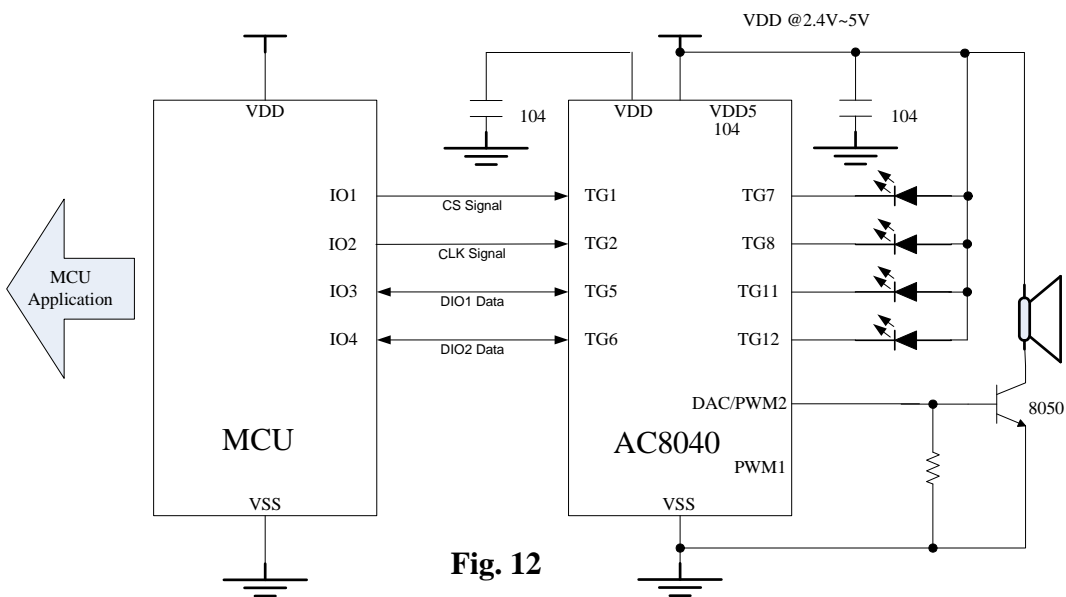
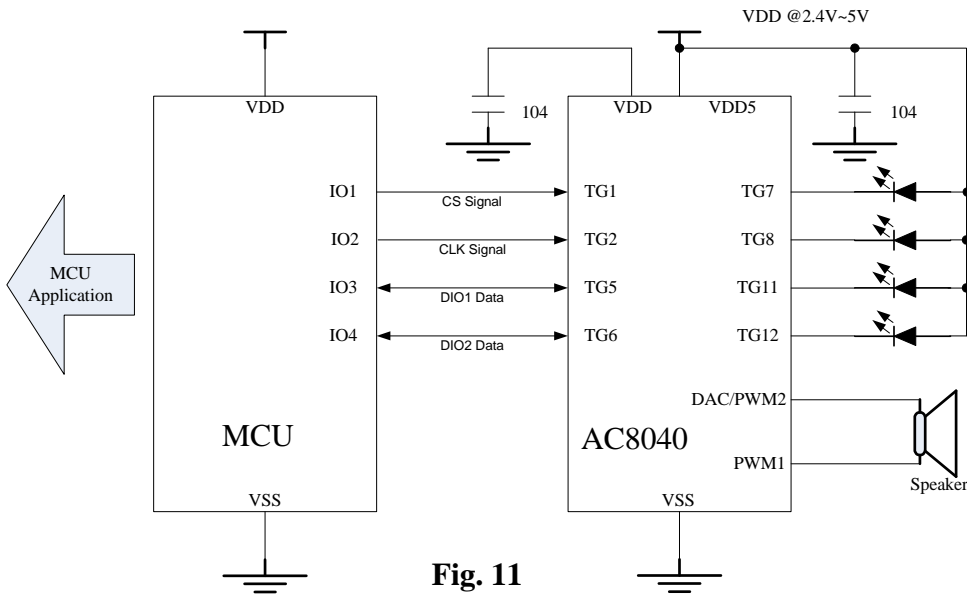



深圳市环芯半导体有限公司

电话 Tel: 0755-28149272

传真 Fax: 29018191

地址 Add: 深圳市宝安区龙华东环一路港之都大厦 633

邮编 Ps.: 518109

Http://www.ATChip.Com

◆ AC8040 Trigger Timing

(a) Trigger Pulse Width < Group Length

Option Setting = Edge / Unhold

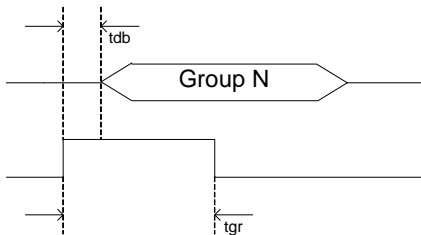

(b) Trigger Pulse Width < Group Length

Option Setting = Edge / Hold

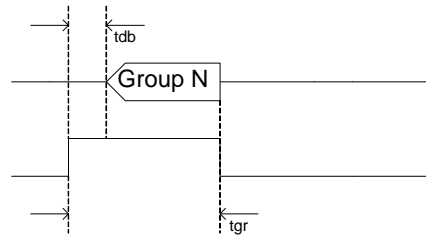

(c) Trigger Pulse Width < Group Length

Option Setting = Level / Unhold

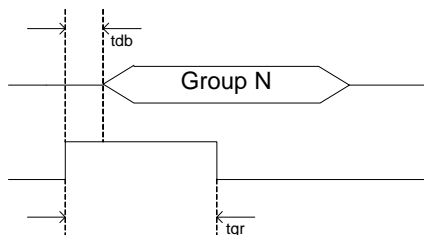

(d) Trigger Pulse Width < Group Length

Option Setting = Level / Hold

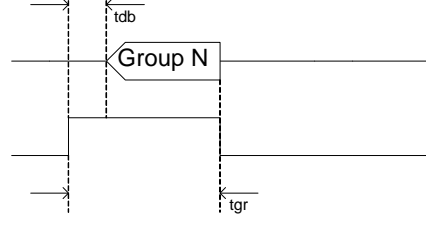

(e) Trigger Pulse Width > Group Length

Option Setting = Edge / Unhold

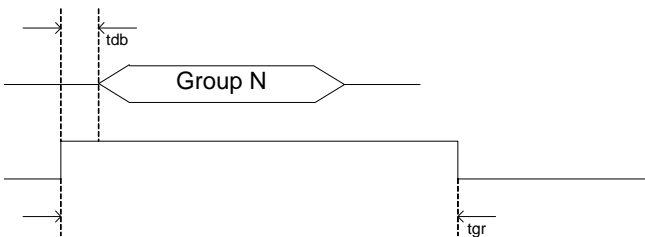

(f) Trigger Pulse Width > Group Length

Option Setting = Edge / Hold

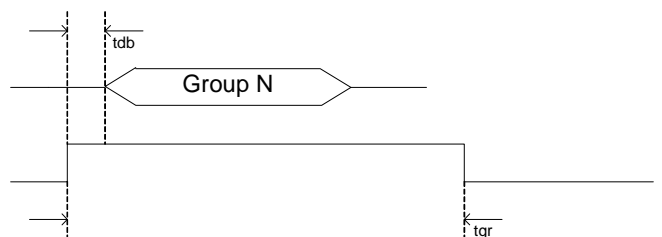

(g) Trigger Pulse Width > Group Length

Option Setting = Level / Unhold

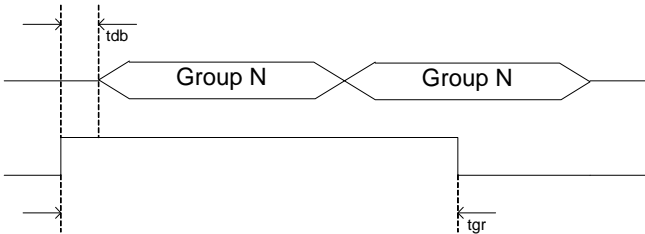

(h) Trigger Pulse Width > Group Length

Option Setting = Level / Hold

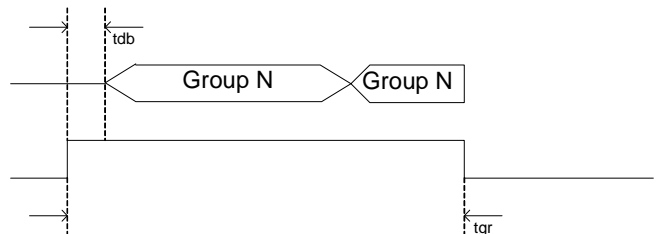



深圳市环芯半导体有限公司

电话 Tel: 0755-28149272

传真 Fax: 29018191

地址 Add: 深圳市宝安区龙华东环一路港之都大厦 633

邮编 Ps.: 518109

Http://www.ATChip.Com

(i) Option Setting = Retrigger

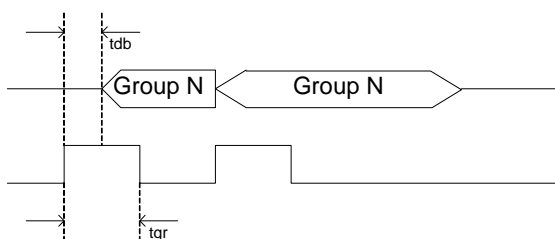

(j) Option Setting = Irretrigger

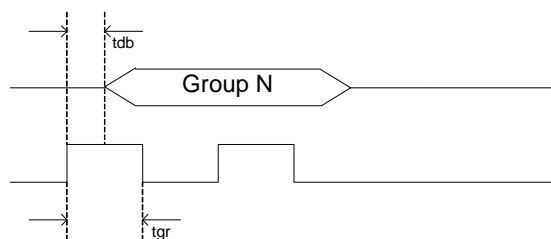

(k) TG1 = Sequential Trigger & From Group1~Group5

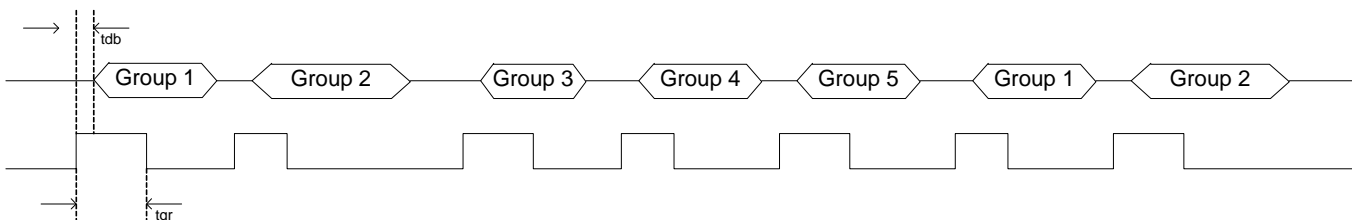



深圳市环芯半导体有限公司

电话 Tel: 0755-28149272

传真 Fax: 29018191

地址 Add: 深圳市宝安区龙华东环一路港之都大厦 633

邮编 Ps.: 518109

Http://www.ATChip.Com

◆ AC8040 Trigger Voice Combination Example

Voice File	Description
Voice File A	Hello (1.5'')
Voice File B	Good Morning (3'')
Voice File C	John (1'')
Voice File D	Tom (1'')
Voice File E	Mary (1.5'')

Group1 = Step1 + Step 2

Group 2 = Step3 + Step 4 + Step 5

Group 3 = Step 6 + Step 7

Group1 = Hello John

Group 2= Hello Tom Good Morning

Group 3 = Good Morning Mary

Step1 = Voice File A

Step 2 = Voice File C

Step 3 = Voice File A

Step 4 = Voice File D

Step 5 = Voice File B

Step 6 = Voice File B

Step 7 = Voice File E

Total use 3 Group , 7 Steps

Voice duration= Hello + Good Morning + John + Tom + Mary

= 1.5'' + 3'' + 1'' + 1'' + 1.5''

= 8''

Total duration = 8'' (40''-8'' = 32'' space are free , can add more Voice File)



深圳市环芯半导体有限公司

电话 Tel: 0755-28149272

传真 Fax: 29018191

地址 Add: 深圳市宝安区龙华东环一路港之都大厦 633

邮编 Ps.: 518109

Http://www.ATChip.Com

◆ AC8040 Serial Mode Timing

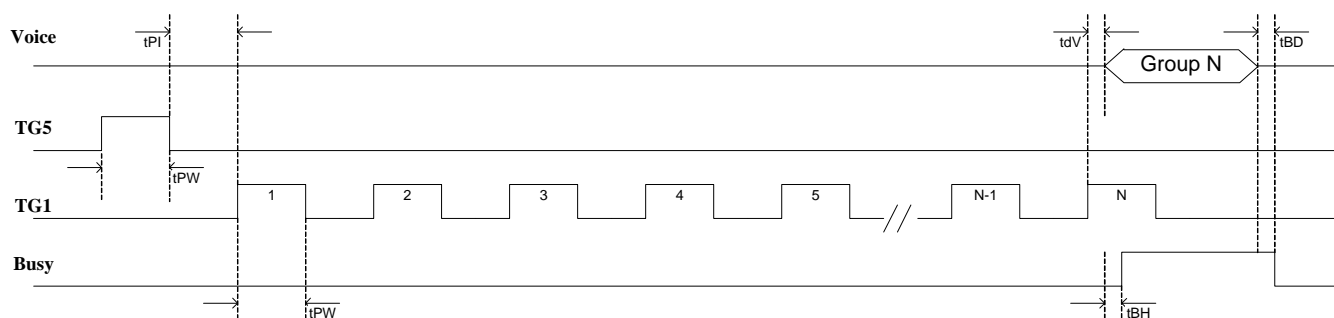

TG1=Edge/Unhold/Retrigger

TG5=Reset PIN



深圳市环芯半导体有限公司

电话 Tel: 0755-28149272

传真 Fax: 29018191

地址 Add: 深圳市宝安区龙华东环一路港之都大厦 633

邮编 Ps.: 518109

Http://www.ATChip.Com

◆ AC8040 CPU Mode Timing

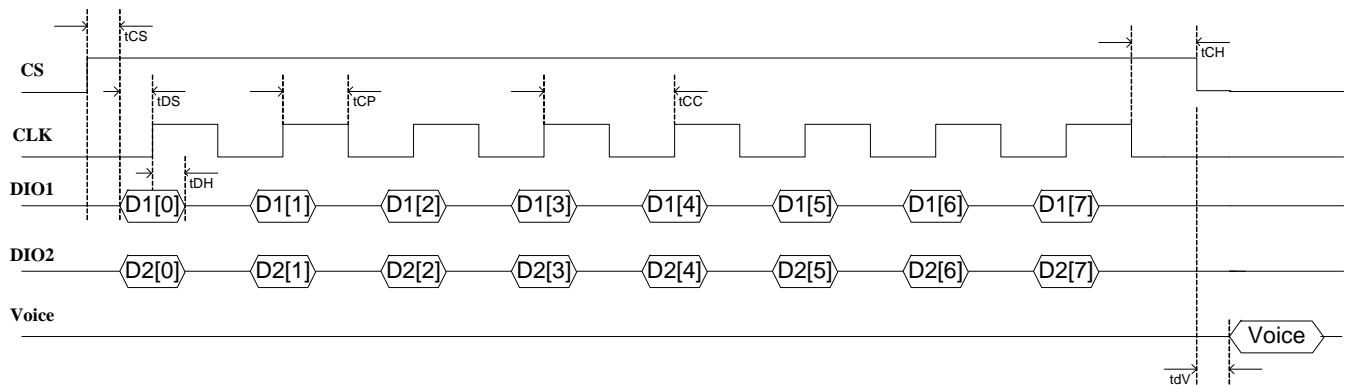

Command	PIN	HEX	[7]	[6]	[5]	[4]	[3]	[2]	[1]	[0]	Description
START	DIO1	A5h	1	0	1	0	0	1	0	1	Wake up the chip
	DIO2	05h	0	0	0	0	0	1	0	1	
END	DIO1	81h	1	0	0	0	0	0	0	1	Power down the chip into standby status
	DIO2	05h	0	0	0	0	0	1	0	1	
RESET	DIO1	83h	1	0	0	0	0	0	1	1	Stop the Playback and wait a new command
	DIO2	02h	0	0	0	0	0	0	1	1	
PAUSE	DIO1	83h	1	0	0	0	0	1	0	1	Pause the Playback and hold at the Voice data
	DIO2	07h	0	0	0	0	0	1	1	1	
RESUME	DIO1	05h	0	0	0	0	0	1	0	1	Resume Playback from the previous Voice data
	DIO2	07h	0	0	0	0	0	1	1	1	

Play Address Command is generated by the Tool.



深圳市环芯半导体有限公司

电话 Tel: 0755-28149272

传真 Fax: 29018191

地址 Add: 深圳市宝安区龙华东环一路港之都大厦 633

邮编 Ps.: 518109

Http://www.ATChip.Com

◆ AC8040 Voice Wave & Output Status

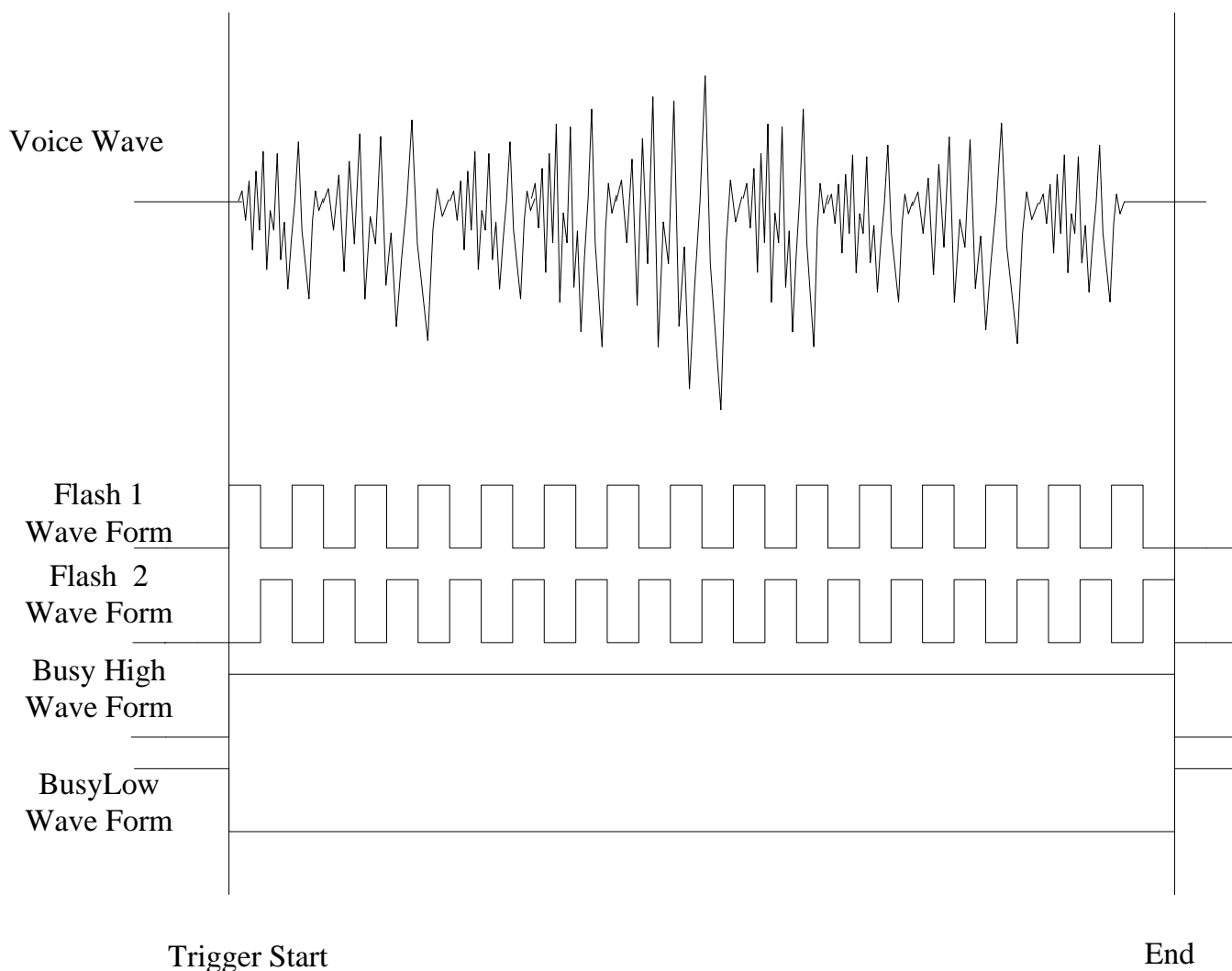



深圳市环芯半导体有限公司

电话 Tel: 0755-28149272

传真 Fax: 29018191

地址 Add: 深圳市宝安区龙华东环一路港之都大厦 633

邮编 Ps.: 518109

Http://www.ATChip.Com

◆ DC Electrical Characteristics

Item	Symbol	Min	Typ	Max	Unit	Condition
Operating voltage	VDD	2.4	3.0	5	V	
Standby current	I _{sb}		1	5	uA	VDD=3V,no load
Operating current	I _{op}		600		uA	VDD=3V,no load
			1		mA	VDD=4.5V,no load
Drive current of Output	I _{od}		10		mA	VDD=3V VOUT=0.6V
Sink current of Output	I _{os}		30		mA	VDD=3V VOUT=2.4V
Drive current of Output	I _{od}		10		mA	VDD=3V(LDO ON) VOUT=0.6V
Sink current of Output	I _{os}		15		mA	VDD=3V(LDO ON) VOUT=2.4V
Drive current of PWM	I _{od}		200		mA	VDD=3V,VOUT=1.5V
Sink current of PWM	I _{os}		200		mA	VDD=3V,VOUT=1.5V



深圳市环芯半导体有限公司

电话 Tel: 0755-28149272

传真 Fax: 29018191

地址 Add: 深圳市宝安区龙华东环一路港之都大厦 633

邮编 Ps.: 518109

Http://www.ATChip.Com

AC Electrical Characteristics

Symbol	Characteristic	Rating			Unit
		Min.	Typ.	Max.	
tdb	Key Trigger debounce time (long)	14			ms
tdb	Key Trigger debounce time (short)	50			us
tgr	Key Trigger Pulse width				
tPW	Serial Mode Input Pulse Width	100			us
tPI	The interval of two pulse	100			us
tBH	Busy signal output hold time	400			us
tBD	Busy signal output delay time	400			us
tdV	Voice output delay time	400			us
tCS	Chip Select setup time	1			us
tDS	Data In setup time	1			us
tDH	Data In hold time	1			us
tCP	Clock Pulse Width	1			us
tCC	Clock Cycle time	2			us
tCH	Chip Select hold time	1			us



深圳市环芯半导体有限公司

电话 Tel: 0755-28149272

传真 Fax: 29018191

地址 Add: 深圳市宝安区龙华东环一路港之都大厦 633

邮编 Ps.: 518109

Http://www.ATChip.Com

AC8040 Package Information

AC8040-S08A

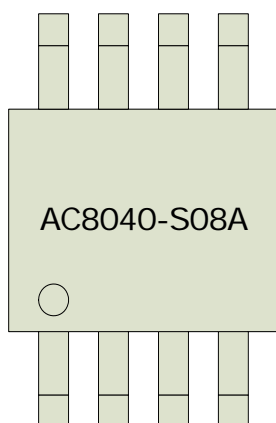

PIN	NAME
1	TG2
2	TG1
3	TG5
4	VSS
5	PWM2/DAC
6	PWM1
7	VDD5
8	VDD

AC8040-D14

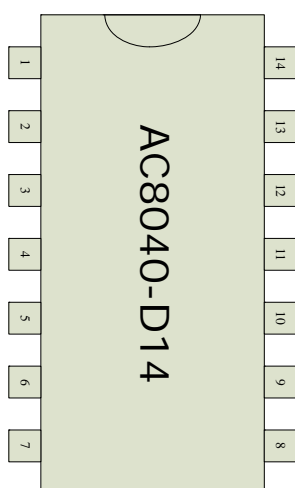

PIN	NAME
1	PWM2/DAC
2	PWM1
3	VDD5
4	VDD
5	VSS
6	TG12
7	TG11
8	TG8
9	NC
10	TG2
11	TG1
12	TG5
13	TG6
14	TG7



深圳市环芯半导体有限公司

电话 Tel: 0755-28149272

传真 Fax: 29018191

地址 Add: 深圳市宝安区龙华东环一路港之都大厦 633

邮编 Ps.: 518109

Http://www.ATChip.Com

◆ Writer Mapping Description

Writer Pin : **TG2,TG1,TG5,VSS,PWM2,PWM1,VDD5,VDD**

DIP 48	PAD Name	AC8040-SO8A	AC8040-D14
10 - RSTN			
11 - GND	9-VSS, 10-VSS	4-VSS	5-VSS
12 - SCK	11-PWM2	5-PWM2	1-PWM2
13 - CS	12-PWM1	6-PWM1	2-PWM1
14 - VCC	13-VDD5, 14-VDD	7-VDD5, 8-VDD	3-VDD5, 4-VDD
36 - TEST			
37 - VPP	1-TG2	1-TG2	10-TG2
38 - DIO1	2-TG1	2-TG1	11-TG1
39 - DIO2	3-TG5	3-TG5	12-TG5

◆ Writer Board Slot Location

